

Maximum Rating Tables

Size 826 • GR, NH, EL Series



Style B

Style H

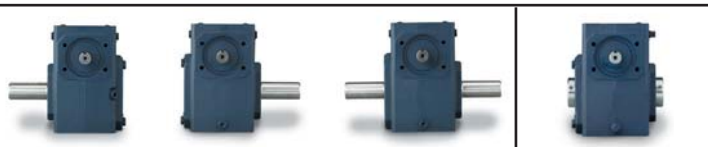

Size 826

Ratio	nput RPM	Output RPM	nput HP	Output HP	Output Torque (lb in)	Left Hand Catalog No	Right Hand Catalog No	Double Extension Catalog No	Hollow Output Catalog No *
5	2500	500	7 946	7 486	944	8260001	8260013	8260025	8260501.XX
	1750	350	6 693	6 276	1130				
	1170	234	5 439	5 061	1363				
	100	20	0 844	0 638	2010				
7.5	2500	333	5 877	5 453	1031	8260002	8260014	8260026	8260502.XX
	1750	233	4 956	4 571	1235				
	1170	156	4 018	3 671	1483				
	100	13	0 640	0 458	2166				
10	2500	250	5 338	4 904	1236	8260003	8260015	8260027	8260503.XX
	1750	175	4 492	4 097	1475				
	1170	117	3 579	3 226	1738				
	100	10	0 572	0 386	2431				
15	2500	166	4 316	3 881	1468	8260004	8260016	8260028	8260504.XX
	1750	116	3 614	3 216	1737				
	1170	78	2 821	2 468	1994				
	100	6 7	0 467	0 279	2637				
20	2500	125	3 503	3 050	1538	8260005	8260017	8260029	8260505.XX
	1750	87	2 965	2 549	1836				
	1170	58	2 339	1 970	2123				
	100	5 0	0 419	0 226	2849				
25	2500	100	2 955	2 505	1579	8260006	8260018	8260030	8260506.XX
	1750	70	2 487	2 076	1869				
	1170	46	1 957	1 594	2146				
	100	4 0	0 370	0 180	2837				
30	2500	83	2 556	2 115	1600	8260007	8260019	8260031	8260507.XX
	1750	58	2 145	1 743	1883				
	1170	39	1 687	1 332	2152				
	100	3 3	0 335	0 149	2816				
40	2500	62	1 989	1 545	1558	8260008	8260020	8260032	8260508.XX
	1750	43	1 695	1 287	1854				
	1170	29	1 354	0 993	2139				
	100	2 5	0 299	0 113	2857				
50	2500	50	1 672	1 237	1560	8260009	8260021	8260033	8260509.XX
	1750	35	1 420	1 023	1843				
	1170	23	1 135	0 784	2112				
	100	2 0	0 269	0 088	2783				
60	2500	41	1 433	1 015	1536	8260010	8260022	8260034	8260510.XX
	1750	29	1 216	0 835	1805				
	1170	19	0 973	0 637	2060				
	100	1 7	0 245	0 071	2689				
80	2500	31	0 659	0 456	919	8260011	8260023	8260035	8260511.XX
	1750	21	0 577	0 379	1092				
	1170	14	0 469	0 289	1247				
	100	1 3	0 070	0 032	1593				
100	2500	25	0 441	0 286	721	8260012	8260024	8260036	8260512.XX
	1750	17	0 386	0 236	851				
	1170	11	0 314	0 179	966				
	100	1 0	0 048	0 019	1222				

How To Build a Part Number For Size GR826, GRG826, GRL826, NH826, EL826

1. Select partial catalog number from the selection table
2. Replace leading “_” with series code (GR, GRG, GRL, NH, EL)
3. For hollow output, replace “XX” suffix with bore code (see next page for codes)

Example:

Grove Gear IRONMAN, hollow output shaft, 5:1 ratio, 180TC coupling input
 GR-HMQ826-5-180TC-19
 GR8260537.19

GRG = GROVE GEAR

- Direct replacement to Grove Gear Flexaline
- 1 1/4” solid output shaft diameter
- For hollow bores specify GRL interchange
- Solid output shaft only



GRL = IRONMAN interchange

- Direct replacement to LEESON RONMAN & major brands
- Hollow shaft option available
- 1 1/8” solid output shaft diameter

Single Reduction
Worm Gear Reducers

Double Reduction
Worm - Worm Gear Reducers

Double Reduction
Helical - Worm Gear Reducers

WASHGUARD® Reducers
and GEAR+MOTOR™

Ratio Multipliers

Accessories and
Additional Capabilities



Maximum Rating Tables

Size 826 • GR, NH, EL Series

NEMA C nput Flange ▲	Style BM			Style HM	Style BMQ			Style HMQ	Ratio
	Left Hand Catalog No	Right Hand Catalog No	Double Extension Catalog No	Hollow Output Catalog No *	Left Hand Catalog No	Right Hand Catalog No	Double Extension Catalog No	Hollow Output Catalog No *	
143 5TC 182 4TC	8260073 8260109	8260085 8260121	8260097 8260133	8260525.XX 8260537.XX	8260181 8260217	8260193 8260229	8260205 8260241	8260561.XX 8260573.XX	5
143 5TC 182 4TC	8260074 8260110	8260086 8260122	8260098 8260134	8260526.XX 8260538.XX	8260182 8260218	8260194 8260230	8260206 8260242	8260562.XX 8260574.XX	7.5
143 5TC 182 4TC	8260075 8260111	8260087 8260123	8260099 8260135	8260527.XX 8260539.XX	8260183 8260219	8260195 8260231	8260207 8260243	8260563.XX 8260575.XX	10
143 5TC 182 4TC	8260076 8260112	8260088 8260124	8260100 8260136	8260528.XX 8260540.XX	8260184 8260220	8260196 8260232	8260208 8260244	8260564.XX 8260576.XX	15
56C 143 5TC 182 4TC	8260041 8260077 8260113	8260053 8260089 8260125	8260065 8260101 8260137	8260517.XX 8260529.XX 8260541.XX	8260149 8260185 8260221	8260161 8260197 8260233	8260173 8260209 8260245	8260553.XX 8260565.XX 8260577.XX	20
56C 143 5TC	8260042 8260078	8260054 8260090	8260066 8260102	8260518.XX 8260530.XX	8260150 8260186	8260162 8260198	8260174 8260210	8260554.XX 8260566.XX	25
56C 143 5TC	8260043 8260079	8260055 8260091	8260067 8260103	8260519.XX 8260531.XX	8260151 8260187	8260163 8260199	8260175 8260211	8260555.XX 8260567.XX	30
56C 143 5TC	8260044 8260080	8260056 8260092	8260068 8260104	8260520.XX 8260532.XX	8260152 8260188	8260164 8260200	8260176 8260212	8260556.XX 8260568.XX	40
56C 143 5TC	8260045 8260081	8260057 8260093	8260069 8260105	8260521.XX 8260533.XX	8260153 8260189	8260165 8260201	8260177 8260213	8260557.XX 8260569.XX	50
56C 143 5TC	8260046 8260082	8260058 8260094	8260070 8260106	8260522.XX 8260534.XX	8260154 8260190	8260166 8260202	8260178 8260214	8260558.XX 8260570.XX	60
56C 143 5TC	8260047 8260083	8260059 8260095	8260071 8260107	8260523.XX 8260535.XX	8260155 8260191	8260167 8260203	8260179 8260215	8260559.XX 8260571.XX	80
56C	8260048	8260060	8260072	8260524.XX	8260156	8260168	8260180	8260560.XX	100

For input/ output shaft overhung load and thrust load ratings, refer to pages 419-422.

▲ Consult Factory for other motor flanges available.

* Catalog numbers are for hollow output shaft reducers.

When ordering, substitute the XX suffix with the required output bore code.

Available bore codes

Fraction Size	1"	1-1/8"	1-3/16"	1-1/4"	1-7/16"	1-1/2"
Decimal Size	1.000	1.125	1.188	1.250	1.438	1.500
Output Bore Code	16	18	19	20	23	24

Single Reduction
Worm Gear Reducers

Double Reduction
Worm - Worm Gear Reducers

Double Reduction
Helical - Worm Gear Reducers

WASHGUARD® Reducers
and GEAR+MOTOR™

Ratio Multipliers

Accessories and
Additional Capabilities



GR Series Dimensions

Styles: HMQ, HM, H

CAST IRON
GR SERIES

Style HMQ

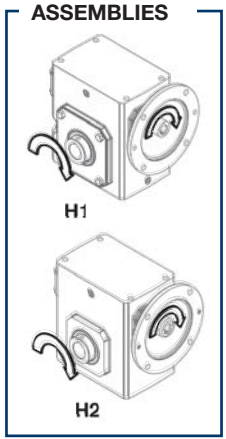
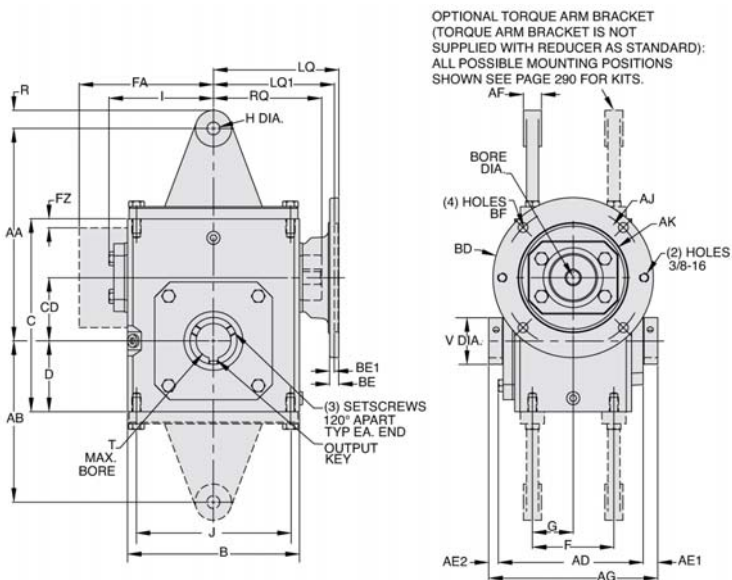

H1 SUPPLIED AS STANDARD UNLESS SPECIFIED.

Style HM

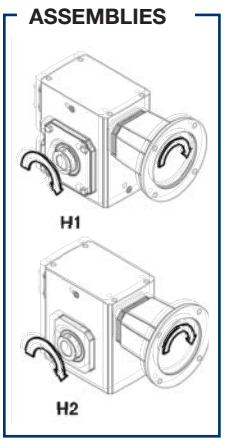
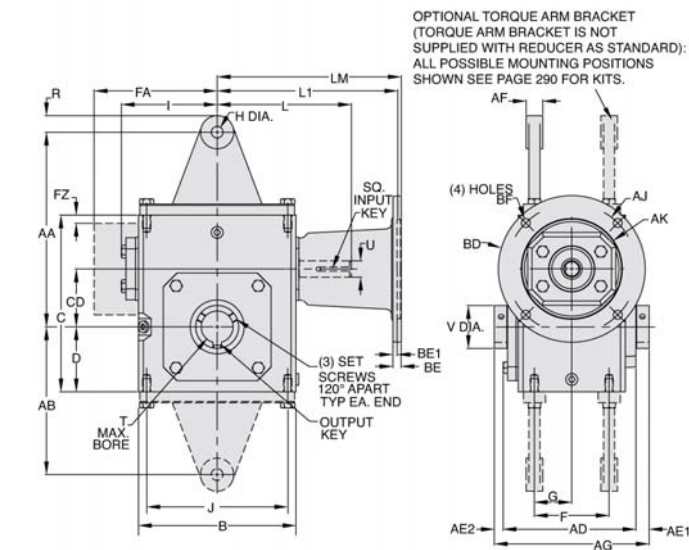

H1 SUPPLIED AS STANDARD UNLESS SPECIFIED.

Style H

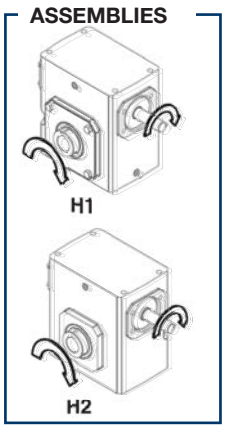
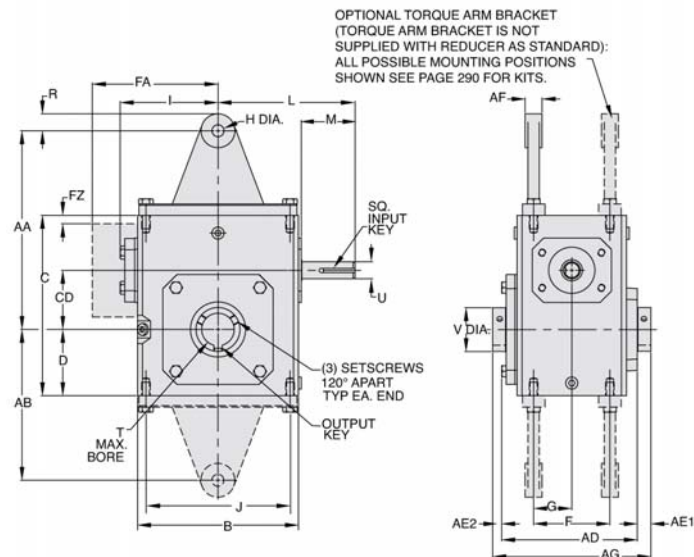

REVERSE ALL ARROWS FOR OPPOSITE INPUT SHAFT ROTATION. CONTACT FACTORY FOR OTHER MOUNTINGS OR ASSEMBLY POSITIONS.

H1 SUPPLIED AS STANDARD UNLESS SPECIFIED.

Single Reduction
Worm Gear Reducers

Double Reduction
Worm - Worm Gear Reducers

Double Reduction
Helical - Worm Gear Reducers

WASHGUARD® Reducers
and GEAR+MOTOR™

Ratio Multipliers

Accessories and
Additional Capabilities



STYLE HMQ, HM, H DIMENSIONS (Inches)

Series	AD	AE1	AE2	AG	B	C	D	CD	F	FA▼	FZ▼	G	I	J	L	M	V	T MAX -0.000 +0.0025	U +0.000 -0.0015	Input Key*	Output Key +
GR813	3.90	0.53	0.32	4.75	3.80	4.66	1.72	1.33	2.00	N/A	N/A	1.00	2.61	3.25	3.82	1.76	1.000	0.625	0.500	1/8 x 1.00	3/16 x 1.50
GR815	4.61	0.51	0.30	5.42	5.19	5.38	1.91	1.54	2.75	N/A	N/A	1.38	3.14	4.19	4.35	1.76	1.000	0.625	0.625	3/16 x 1.38	3/16 x 1.50
GR818	4.73	0.49	0.28	5.50	5.19	5.75	2.06	1.75	2.75	N/A	N/A	1.38	3.24	4.19	4.45	1.76	1.440	1.000	0.625	3/16 x 1.38	1/4 x 3.00
GR821	4.99	0.61	0.40	6.00	5.80	6.38	2.28	2.06	▲	N/A	N/A	1.44	3.61	▲	4.82	1.76	1.940	1.500	0.625	3/16 x 1.38	3/8 x 3.00
GR824	5.18	0.51	0.31	6.00	6.12	6.94	2.50	2.38	2.88	N/A	N/A	1.44	3.77	5.00	5.51	2.38	1.940	1.500	0.750	3/16 x 1.63	3/8 x 3.00
GR826x	6.01	0.60	0.39	7.00	7.38	8.00	2.94	2.63	3.38	N/A	N/A	1.69	4.34	6.38	6.07	2.38	1.940	1.500	0.750	3/16 x 1.63	3/8 x 3.00
GR830	6.53	0.60	0.36	7.50	8.12	8.88	3.25	3.00	4.00	N/A	N/A	2.00	4.84	7.00	6.57	2.38	2.756	2.188	0.875	3/16 x 1.63	1/2 x 3.00
GR832x	7.04	0.54	0.29	7.88	8.75	9.38	3.50	3.25	4.00	N/A	N/A	2.00	5.02	7.50	6.76	2.38	2.756	2.188	0.875	3/16 x 1.63	1/2 x 3.00
GR842	7.53	0.63	0.34	8.50	10.25	11.38	4.44	4.25	5.00	N/A	N/A	2.50	6.10	8.50	9.57	3.47	2.756	2.188	1.250	1/4 x 2.50	1/2 x 3.00
GR852	8.85	0.97	0.68	10.50	13.00	14.00	5.12	5.25	5.81	N/A	N/A	2.91	7.50	11.00	10.88	3.38	4.260	3.438	1.250	1/4 x3.00	7/8 x3.44
GR860	10.52	0.52	0.52	11.50	14.50	16.50	6.50	6.00	6.38	11.13	0.33	3.19	N/A	12.75	11.78	3.41	4.256	3.438	1.500	3/8 x 3.00	7/8 x 3.44
GR870	11.36	1.09	1.09	13.50	14.88	18.91	7.59	7.00	5.50	11.37	0.35	2.75	N/A	12.50	11.50	2.97	4.928	3.938	1.625	3/8 x 2.87**	1 x 1/2**
GR880	12.48	1.03	1.03	14.50	17.00	20.96	8.86	8.00	6.50	12.52	0.57	3.25	N/A	14.25	12.50	2.84	5.553	4.438	1.875	1/2 x 2.81**	1 x 1/2**
GR8100	15.78	1.39	1.39	18.50	20.88	25.47	10.36	10.00	6.88	14.69	0.51	3.44	N/A	14.75	15.50	3.76	4.256	5.438	2.250	1/2 x 3.69**	1-1/4 x 5/8**

▲ See feature comparison chart.

FEATURE COMPARISON (821)

Size	Output Shaft Diameter Needed?	Mounting Footprint Needed?	Output Key Needed?	All Other Features	Grove Gear Flexaline Interchange	LEESON IRONMAN Interchange	Replace With Series Code Below:
GR821	Identical	(F)3.00" x (J)4.75" (F)2.88" x (J)5.00"	Identical	Identical	✓	✓	GRG GRL

NOTE: If reducer is used without the accessory mounted, select based mounting dimensions on pages 52-53 (B, BM, BMQ).

**Motor Mounting Dimensions
NEMA DIMENSIONS (Inches)**

Size	48CZ	LM	56C/140TC	180TC/210TC	L1	250TC	LQ	48CZ/56C/140TC	180TC	LQ1	210TC	250TC	48CZ/56C/140TC	180TC	210TC	250TC
GR813	5.63	6.07	N/A	N/A	N/A	N/A	3.46	N/A	N/A	N/A	N/A	N/A	3.09	N/A	N/A	N/A
GR815	6.16	6.60	N/A	N/A	N/A	N/A	3.99	N/A	N/A	N/A	N/A	N/A	3.62	N/A	N/A	N/A
GR818	6.26	6.70	N/A	N/A	N/A	N/A	4.09	N/A	N/A	N/A	N/A	N/A	3.59	N/A	N/A	N/A
GR821*	6.63	7.07	N/A	N/A	N/A	N/A	4.46	N/A	N/A	N/A	N/A	N/A	4.06	N/A	N/A	N/A
GR824	N/A	7.76	8.76	N/A	4.63	5.06	N/A	4.09	4.56	N/A	N/A	N/A	4.09	4.56	N/A	N/A
GR826*	N/A	8.32	9.32	N/A	5.19	5.62	N/A	4.82	5.13	N/A	N/A	N/A	5.13	N/A	N/A	N/A
GR830	N/A	8.82	9.82	N/A	5.95	6.15	6.56	N/A	5.32	5.63	6.06	N/A	5.63	6.06	N/A	N/A
GR832*	N/A	9.01	10.01	N/A	6.14	6.34	6.75	N/A	5.51	5.81	6.25	N/A	5.81	6.25	N/A	N/A
GR842	N/A	11.81	12.90	13.46	6.45	7.21	7.21	7.77	6.04	6.68	6.68	7.24	6.68	6.68	7.24	7.24
GR852	N/A	13.21	14.30	14.86	7.85	8.61	8.61	9.17	7.35	7.98	7.98	8.54	7.98	7.98	8.54	8.54
GR860	N/A	N/A	15.88	16.50	10.45	9.33	9.33	9.94	10.01	8.69	8.69	8.69	8.69	8.69	8.69	8.69
GR870	N/A	N/A	15.50	15.50	N/A	N/A	N/A	N/A	N/A	N/A	N/A	N/A	N/A	N/A	N/A	N/A
GR880	N/A	N/A	16.58	16.58	N/A	N/A	N/A	N/A	N/A	N/A	N/A	N/A	N/A	N/A	N/A	N/A

NEMA DIMENSIONS (Inches)

Frame	AJb	AK	BD	BE	BE1	Bore Dia.	Keyway♦	BFb
	3.75	3.00	4.36	0.38	N/A	.500	1/8 X 1/16	0.28
56C	5.88	4.50	6.50	0.38	N/A	.625	3/16 X 3/32	0.41
140TC	5.88	4.50	6.50	0.38	N/A	.875	3/16 X 3/32	0.41
180TC	7.25	8.50	9.00	N/A	0.50	1.125	1/4 X 1/8	0.53
210TC	7.25	8.50	9.00	N/A	0.50	1.375	5/16 X 5/32	0.53
250TC	7.25	8.50	9.00	N/A	0.50	1.625	3/8 X 3/16	0.53

IEC B5 & B3/B5 METRIC DIMENSIONS (Inches)*

Size	LQ1						RQ					
	D63D	D71D	D80D	D90D	D100LD/D112MD	D132D	D63D	D71D	D80D	D90D	D100LD/D112MD	D132D
GR813	2.62	2.65	2.89	N/A	N/A	N/A	2.45	2.47	2.71	N/A	N/A	N/A
GR815	3.15	3.18	3.42	N/A	N/A	N/A	2.98	3.00	3.24	N/A	N/A	N/A
GR818	3.25	3.28	3.52	N/A	N/A	N/A	2.95	2.97	3.21	N/A	N/A	N/A
GR821*	3.62	3.65	3.89	N/A	N/A	N/A	3.43	3.44	3.68	N/A	N/A	N/A
GR824	N/A	3.72	4.34	N/A	N/A	N/A	3.46	3.71	N/A	N/A	N/A	N/A
GR826*	N/A	4.28	4.90	4.90	5.30	N/A	N/A	4.09	4.72	4.72	5.07	N/A
GR830	N/A	4.78	5.41	5.41	5.88	N/A	N/A	4.59	5.22	5.22	5.57	N/A
GR832*	N/A	4.97	5.59	5.59	6.07	N/A	N/A	4.78	5.41	5.41	5.76	N/A
GR842	N/A	N/A	N/A	6.38	6.39	7.17	N/A	N/A	N/A	6.16	6.14	6.93
GR852	N/A	N/A	N/A	7.78	7.78	8.57	N/A	N/A	N/A	7.46	7.45	8.24

IEC B5 & B3/B5 METRIC DIMENSIONS (MM)

Frame	AJ	AK	BD	BE	Bore Dia.	Keyway♦	BF TAP	OD
D63D	115	95	117	10	11	4 X 2	M8 X 1.25	131
D71D	130	110	132	11	14	5 X 2.5	M8 X 1.25	146
D80D	165	130	165	15	19	6 X 3	M10 X 1.50	184
D90D	165	130	165	15	24	8 X 3.5	M10 X 1.50	184
D100LD/D112MD	215	180	216	18	28	8 X 3.5	M12 X 1.75	237
D132D	265	230	267	18	38	10 X 4	M12 X 1.75	290

* Max bore dimensions shown. For additional bores available, refer to page 20.

* Applies to double output shaft

** Key not provided with gear reducer. Keyway dimension shown.

♦ Keyway width by depth

⊙ Mounting holes rotated 45 degrees from positions shown on Size GR860, Style HM with frame sizes 180TC-250TC.

■ 48CZ not available

● 180TC not available

⊕ Metric IEC B5 input flange options are available only on quill input styles.

* Dimensions same for GRG and GRL Series

* Style H and HM only.

▼ Sizes 860-8100 are supplied with a fan. Dimensions refer to fan guard location.

Note: Torque arm bracket available separately. Refer to page 274 for kits. If a special bracket is required, refer to Style BMQ dimensions for mounting pad dimensions on top/bottom of reducer.



For safety, purchaser or user should provide protective guards over shaft extensions and any couplings, sheaves and belts, sprockets and chains, etc., mounted thereon.

Single Reduction
Worm Gear Reducers

Double Reduction
Worm - Worm Gear Reducers

Double Reduction
Helical - Worm Gear Reducers

WASHGARD® Reducers
and GEAR-HMOTOR™

Ratio Multipliers

Accessories and
Additional Capabilities